

## Bronze Sleeve Packed Water Gauge

Fig. 505

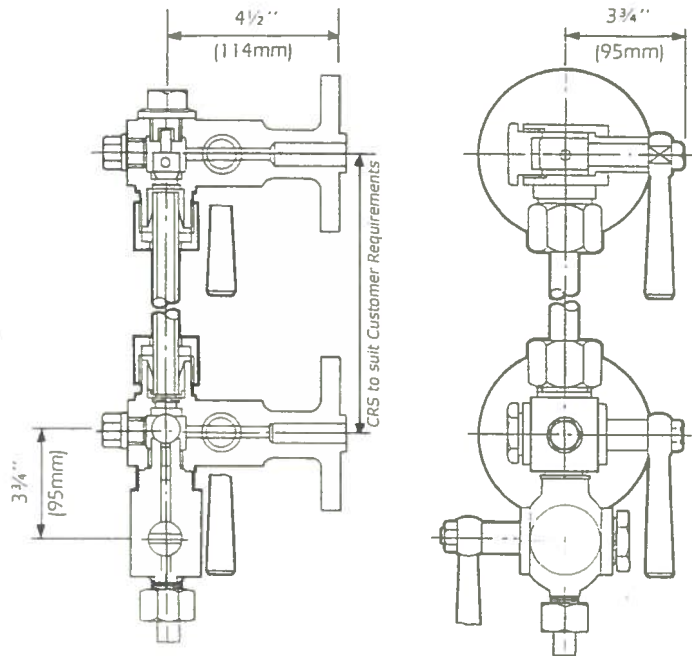

## Technical Description of Standard Gauge

Cast Bronze Body and Trycock,  
Manganese Bronze  
Fittings and PTFE Packing Sleeves  
Automatic Shut Off in both Top and  
Bottom Arms should Gauge Glass  
break.  
Flanged to ANSI, BS. or European  
Standards

### When Ordering Please State:

1. Size of Gauge Glass required i.e. 1/2" or 3/4"
2. Distance between centres of top and bottom arms
3. Whether Left or Right Hand Gauge required
4. Whether Protector required. Fig. 514
5. Whether Reflex required. Fig. 614

**Weight 9.6 KG**

Maximum Working Conditions when fitted with Tubular Glass

STEAMING		NON STEAMING	
BAR	LB/IN <sup>2</sup>	BAR	LB/IN <sup>2</sup>
18.5	268	24	350

Maximum Working Conditions when fitted with Reflex Indicator Fig.614.

STEAMING	NON STEAMING
24 BAR	350 LB/IN <sup>2</sup>